

Package Dimensions

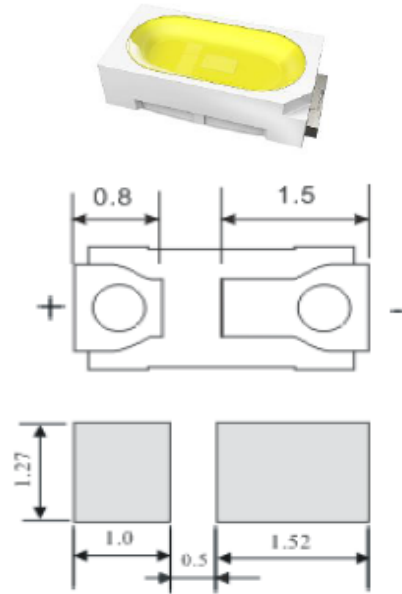
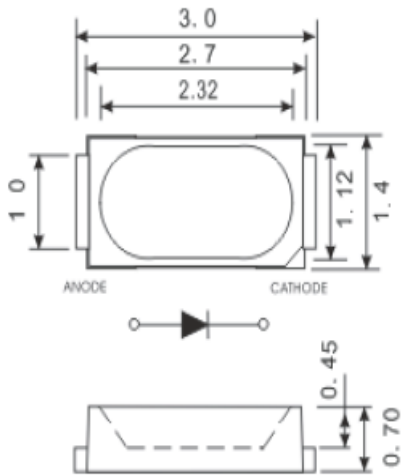

2. SPECIFICATIONS

Absolute Maximum Rating

Item	Symbol	Absolute Maximum Rating	Unit
Forward Current	IF	30	mA
Pulse Forward Current	IFP	150	mA
Reverse Voltage	VR	5	V
Power Dissipation	PD	108	mW
Junction Temperature	Tj	120	°C
Operating Temperature	Topr	-40~+85	°C
Storage Temperature	Tstg	-40~+100	°C
Soldering Temperature	Tsld	Manual: 300°C for 2sec.(max) 300°C for 2sec Reflow: Reference Reflow Profile.	

Initial Electrical /Optical Characteristics

Item	Symbol	Condition	Min	Typ	Max	Unit
Forward Voltage	VF		3.0		3.6	V
Luminous Flux	ϕ_v	IF=30mA	--	12	--	LM
Viewing Angle	2θ _{1/2}		--	120	--	Deg
Reverse Current	IR	VR=5V	--		10	μA

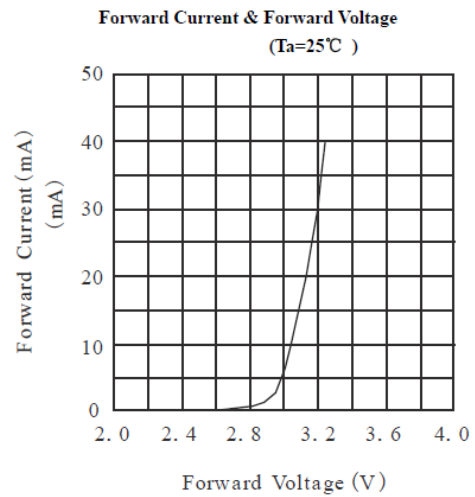
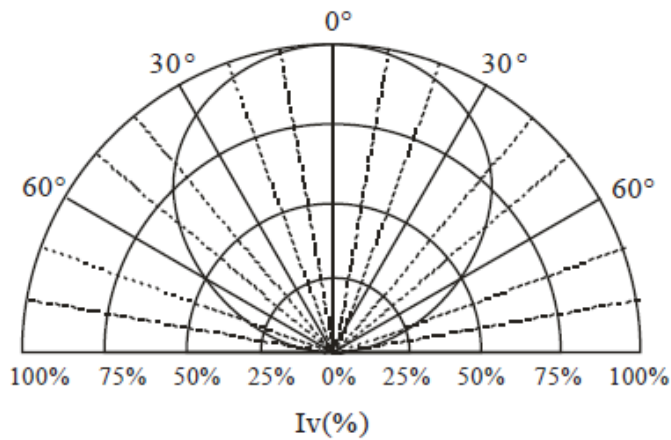
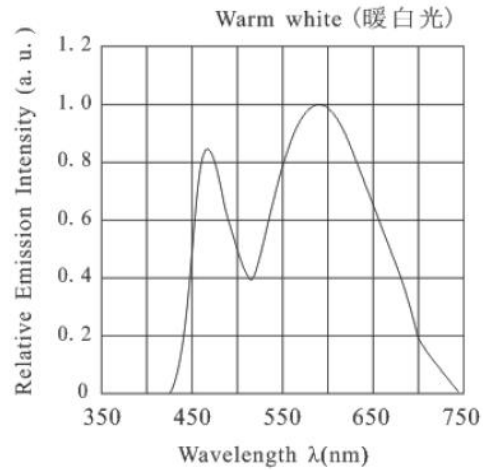
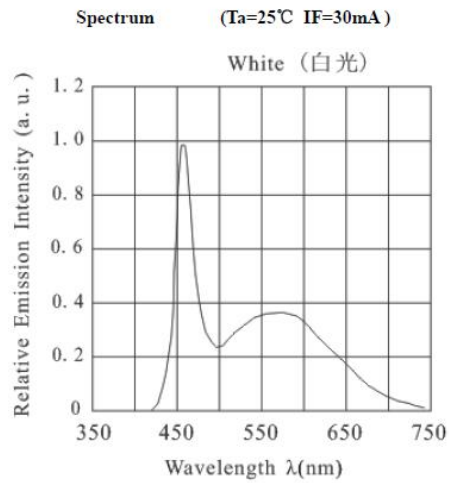

Relative Luminous Flux & Forward Current

Allowable Forward Current & Ambient Temperature

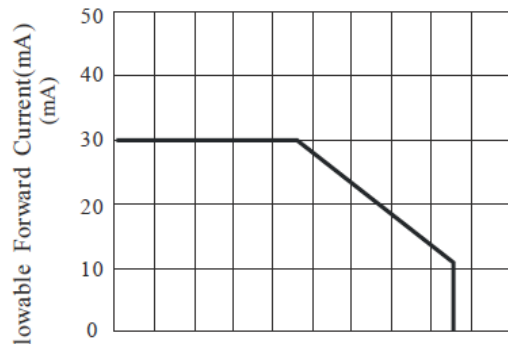
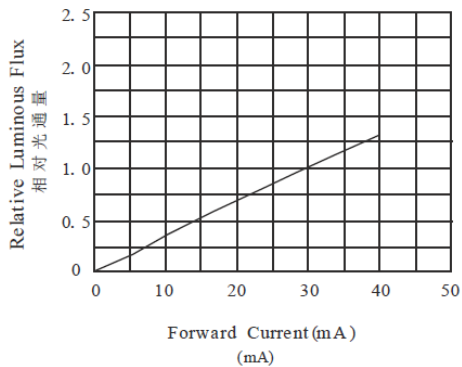

kwality

KWALITY PHOTONICS PRIVATE LIMITED

ISO 9001-2008

29, EC Kushaiguda, Hyderabad-50 062, INDIA. PH:91-040-27123555,27136252

Email: sales@kwalityindia.com www.kwalityindia.com